



# MICROWAVE OVEN

CE117KB

# *SERVICE* Manual

MICROWAVE OVEN

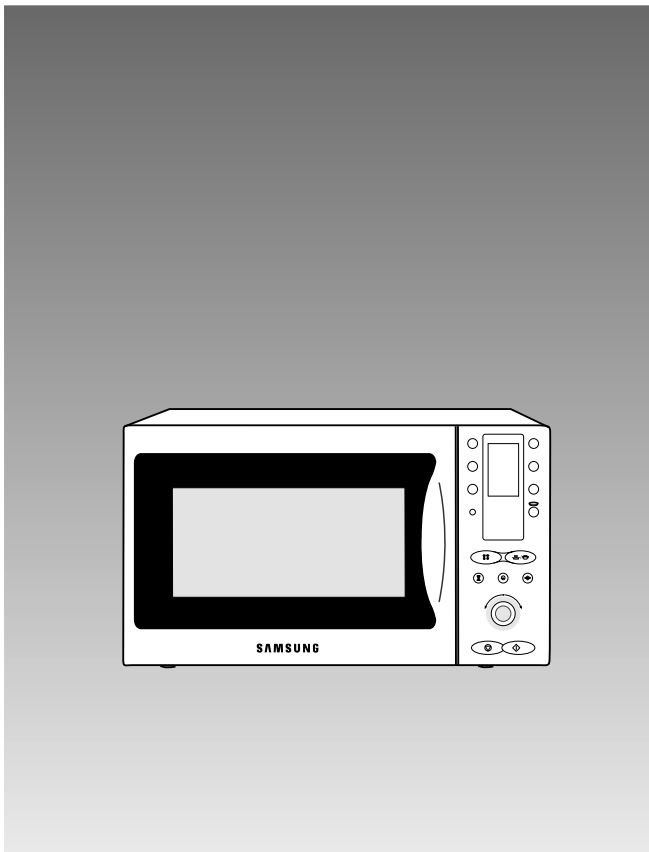

SECOSA

CONTENTS

1. Precaution
2. Specifications
3. Operating Instructions
4. Disassembly and Reassembly
5. Alignment and Adjustments
6. Troubleshooting
7. Exploded Views and Parts List
8. PCB Diagrams
9. Schematic Diagrams

## **PRECAUTIONS TO BE OBSERVED BEFORE AND DURING SERVICING TO AVOID POSSIBLE EXPOSURE TO EXCESSIVE MICROWAVE ENERGY**

- (a) Do not operate or allow the oven to be operated with the door open.
- (b) Make the following safety checks on all ovens to be serviced before activating the magnetron or other microwave source, and make repairs as necessary:
  - (1) Interlock operation,
  - (2) proper door closing,
  - (3) seal and sealing surfaces (arcing, wear, and other damage),
  - (4) damage to or loosening of hinges and latches,
  - (5) evidence of dropping or abuse.
- (c) Before turning on microwave power for any service test or inspection within the microwave generating compartments, check the magnetron, wave guide or transmission line, and cavity for proper alignment, integrity, and connections.
- (d) Any defective or misadjusted components in the interlock, monitor, door seal, and microwave generation and transmission systems shall be repaired, replaced, or adjusted by procedures described in this manual before the oven is released to the owner.
- (e) A Microwave leakage check to verify compliance with the Federal performance standard should be performed on each oven prior to release to the owner.

---

# 1. Precaution

---

Follow these special safety precautions. Although the microwave oven is completely safe during ordinary use, repair work can be extremely hazardous due to possible exposure to microwave radiation, as well as potentially lethal high voltages and currents.

## 1-1 Safety precautions ( )

---

1. All repairs should be done in accordance with the procedures described in this manual. This product complies with Federal Performance Standard 21 CFR Subchapter J (DHHS).
2. Microwave emission check should be performed prior to servicing if the oven is operative.
3. If the oven operates with the door open : Instruct the user not to operate the oven and contact the manufacturer and the center for devices and radiological health immediately.
4. Notify the Central Service Center if the microwave leakage exceeds 5 mW/cm<sup>2</sup>
5. Check all grounds.
6. Do not power the MWO from a "2-prong" AC cord. Be sure that all of the built-in protective devices are replaced. Restore any missing protective shields.
7. When reinstalling the chassis and its assemblies, be sure to restore all protective devices, including: nonmetallic control knobs and compartment covers.
8. Make sure that there are no cabinet openings through which people--particularly children--might insert objects and contact dangerous voltages. Examples: Lamp hole, ventilation slots.
9. Inform the manufacturer of any oven found to have emission in excess of 5 mW/cm<sup>2</sup>, Make repairs to bring the unit into compliance at no cost to owner and try to determine cause. Instruct owner not to use oven until it has been brought into compliance.
10. Service technicians should remove their watches while repairing an MWO.
11. To avoid any possible radiation hazard, replace parts in accordance with the wiring diagram. Also, use only the exact replacements for the following parts: Primary and secondary interlock switches, interlock monitor switch.
12. If the fuse is blown by the Interlock Monitor Switch: Replace all of the following at the same time: Primary and secondary switches, as well as the Interlock Monitor Switch. The correct adjustment of these switches is described elsewhere in this manual. Make sure that the fuse has the correct rating for the particular model being repaired.
13. Design Alteration Warning: Use exact replacement parts only, i.e., only those that are specified in the drawings and parts lists of this manual. This is especially important for the Interlock switches, described above. Never alter or add to the mechanical or electrical design of the MWO. Any design changes or additions will void the manufacturer's warranty.10.Always unplug the unit's AC power cord from the AC power source before attempting to remove or reinstall any component or assembly.
14. Never defeat any of the B+ voltage interlocks. Do not apply AC power to the unit (or any of its assemblies) unless all solid-state heat sinks are correctly installed.

**SAMSUNG ELECTRONICS COMERCIAL  
IBERICA, S. A  
VIA AUGUSTA, PARCELA 103  
08184 PALAU DE PLEGAMANS  
BARCELONA, ESPANA**

## 1-2 Special Servicing Precautions (Continued)

- Some semiconductor ("solid state") devices are easily damaged by static electricity. Such components are called Electrostatically Sensitive Devices (ESDs). Examples include integrated circuits and field-effect transistors.

Immediately before handling any semiconductor components or assemblies, drain the electrostatic charge from your body by touching a known earth ground.

- Always connect a test instrument's ground lead to the instrument chassis ground *before* connecting the positive lead; always remove the instrument's ground lead last.

- When checking the continuity of the switches or transformer, always make sure that the power is OFF, and one of the lead wires is disconnected.

- Components that are critical for safety are indicated in the circuit diagram by shading, ▲ or ▲.

- Use replacement components that have the same ratings, especially for flame resistance and dielectric strength specifications. A replacement part that does not have the same safety characteristics as the original might create shock, fire or other hazards.

## 1-3 Special High Voltage Precautions

- High Voltage Warning**  
Do not attempt to measure any of the high voltages--this includes the filament voltage of the magnetron. High voltage is present during any cook cycle.

Before touching any components or wiring, always unplug the oven and discharge the high voltage capacitor (See Figure 1-1)

- The high-voltage capacitor remains charged about 30 seconds after disconnection. Short the negative terminal of the high-voltage capacitor to the oven chassis. (Use a screwdriver.)
- High voltage is maintained within specified limits by close-tolerance, safety-related components and adjustments. If the high voltage exceeds the specified limits, check each of the special components.

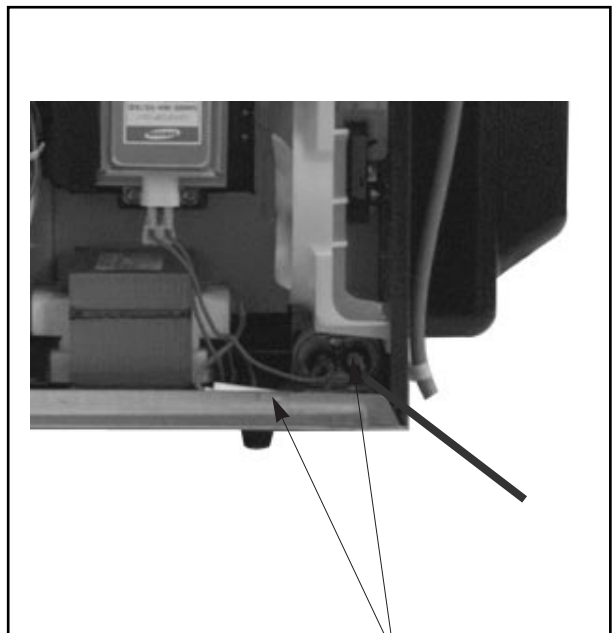

- ☞ : Touch chassis side first then short to the high voltage capacitor terminal by using a screwdriver or jumper wire.

### PRECAUTION

There exists HIGH VOLTAGE ELECTRICITY with high current capabilities in the circuits of the HIGH VOLTAGE TRANSFORMER secondary and filament terminals. It is extremely dangerous to work on or near these circuits with the oven energized.  
DO NOT measure the voltage in the high voltage circuit including filament voltage of magnetron.

### PRECAUTION

Never touch any circuit wiring with your hand nor with an insulated tool during operation.

### PRECAUTION

Servicemen should remove their watches whenever working close to or replacing the magnetron.

## 2. Specifications

### 2-1 Table of Specifications

ITEM	MODEL	CE117KB
TIMER		99 MINUTES 90 SECONDS
POWER SOURCE		230V/50HZ, AC
POWER CONSUMPTION		MICROWAVE : 1,500W
OUTPUT POWER		900W (10LEVEL POWER) (IEC-705 TEST PROCEDURE)
OPERATING FREQUENCY		2,450MHz
MAGNETRON		OM75PH(31)
COOLING METHOD		COOLING FAN MOTOR
OUTSIDE DIMENSIONS		547(W) x 339(H) x 528(D)
NET WEIGHT		26 Kg
SHIPPING WEIGHT		30 Kg

### 2-2 Comparison Chart

MODE	CE117KB
MORE/LESS	i
AUTO REHEAT/COOK	i
AUTO DEFROST	i
TIME COOK	i
POWER LEVEL	i
CONVECTION	i
GRILL	i
MICROWAVE+CONVECTION	i
MICROWAVE+GRILL	i
CONVECTION+GRILL	i
PREHEAT	i
DIODORIZATION	i
BARBECUE SPIT	i

---

## 4. Disassembly and Reassembly

---

### 4-1 Replacement of Magnetron, Motor Assembly and Lamp

---

Remove the magnetron including the shield case, permanent magnet, choke coils and capacitors (all of which are contained in one assembly).

1. Disconnect all lead wires from the magnetron and lamp.
2. Remove the bracket mounting.
3. Remove the magnetron supporter
4. Remove the air cover.
5. Remove screws securing the magnetron to the wave guide.
6. Take out the magnetron very carefully.
7. Remove screws from the back panel.
8. Remove the assy noise filter.
9. Take out the fan motor.
10. Remove the oven lamp by pulling out from hole of air cover carefully.

NOTE1: When removing the magnetron, make sure that its antenna does not hit any adjacent parts, or it may be damaged.

NOTE2: When replacing the magnetron, be sure to remount the magnetron gasket in the correct position and make sure the gasket is in good condition.

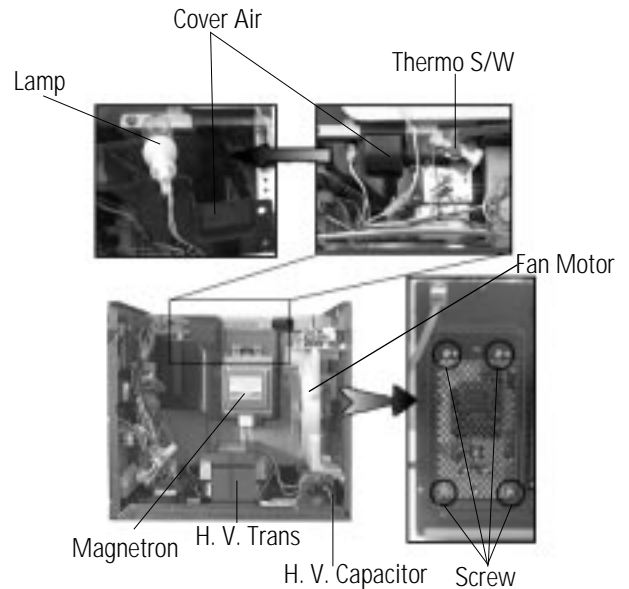

### 4-2 Replacement of High Voltage Transformer

---

1. Discharge the high voltage capacitor.
2. Disconnect all the leads.
3. Remove the mounting bolts.
4. Reconnect the leads correctly and firmly.

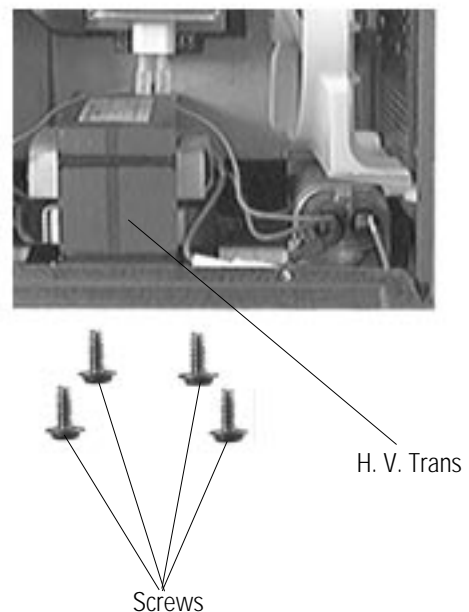

### 4-3 Replacement of Door Assembly

#### 4-3-1 Removal of Door Assembly

Remove screws securing the upper hinge and lower hinge. Then remove the door assembly.

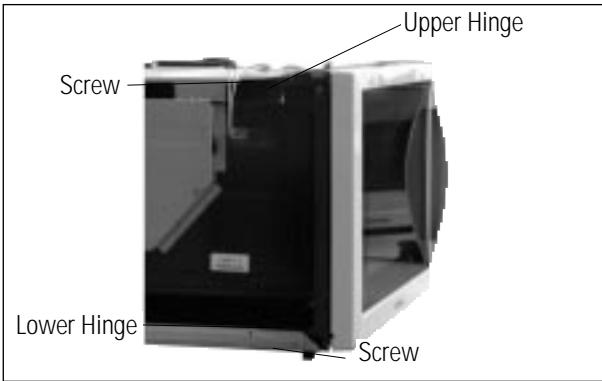

#### 4-3-4 Removal of Key Door & Spring

Remove pin hinge from Door "E"  
Detach spring from Door "E" and key door.

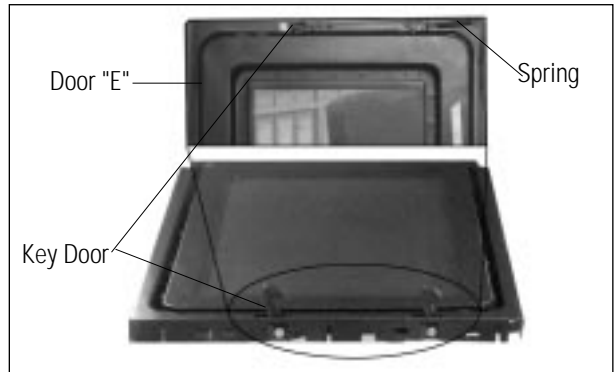

#### 4-3-2 Removal of Door "C"

Insert flat screwdriver into the gap between Door "A" and Door "C" to remove Door "C". Be careful when handling Door "C" because it is fragile.

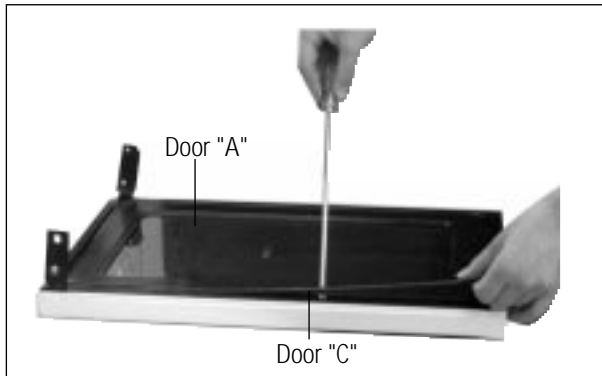

#### 4-3-5 Removal of Screen-Door & Sub-Door

1. Remove Door "E" from Door "A".
2. Remove Door-Screen "B" and Sub Door.

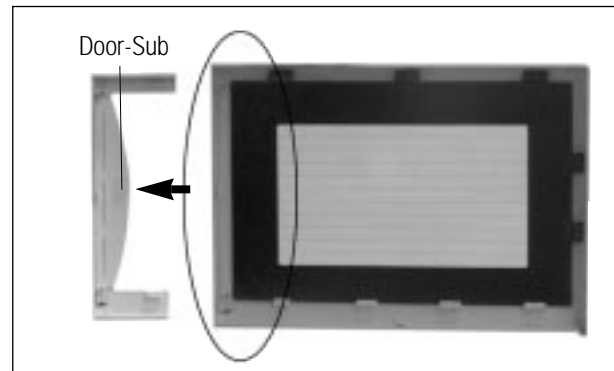

#### 4-3-3 Removal of Door "E"

Following the procedure as shown in the figure, insert and bend a thin metal plate between Door "E" and Door "A" until you hear the 'tick' sound.



1. Insertion depth of the thin metal plate should be 0.5mm or less.

### 4-3-5 Reassembly Test

After replacement of the defective component parts of the door, reassemble it and follow the instructions below for proper installation and adjustment so as to prevent an excessive microwave leakage.

1. When mounting the door to the oven, be sure to adjust the door parallel to the bottom line of the oven face plate by moving the upper hinge and lower hinge in the direction necessary for proper alignment.
2. Adjust so that the door has no play between the inner door surface and oven front surface. If the door assembly is not mounted properly, microwave energy may leak from the space between the door and oven.
3. Do the microwave leakage test.

### 4-4 Replacement of Fuse

1. Disconnect the oven from the power source.
2. Remove the 10A fuse in the Noise filter.
3. When replacing the 10A fuse, be sure to use an exact replacement part. If new 10A fuse blows out again after replacement, check the primary interlock switch, door sensing switch and interlock monitor switch.
4. When the above three switches operate properly, check if any other part such as the control circuit board, blower motor or high voltage transformer is defective.

### 4-5 Replacement of Drive Motor

1. Take out the glass tray and guide roller from the cavity.
2. Turn the oven upside down to replace the drive motor.
3. Remove a screw securing the drive motor cover.
4. Disconnect all the lead wires from the drive motor.
5. Remove screws securing the drive motor to the cavity.
6. Remove the drive motor and coupler.
7. When replacing the drive motor, be sure to remount it in the correct position with the coupler.
8. Connect all the leads to the drive motor.
9. Screw the drive motor cover to the base plate with a screw driver.

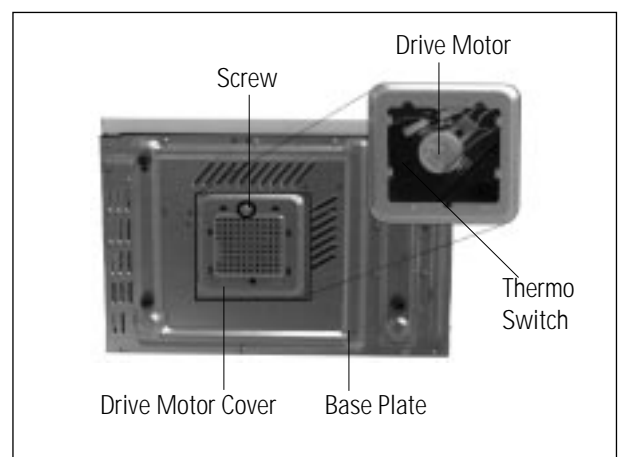

## 4-6 Replacement of Control Circuit Board

### 4-6-1 Removal of Control Box Assembly

1. Be sure to discharge any static electricity from your body, and avoid touching the "Touch control" circuitry.
2. Disconnect the connectors from the control circuit board.
3. Remove screws securing the control circuit board.
4. Lift up the control circuit board from right side and remove the hooks holding the control circuit board to the box assembly.

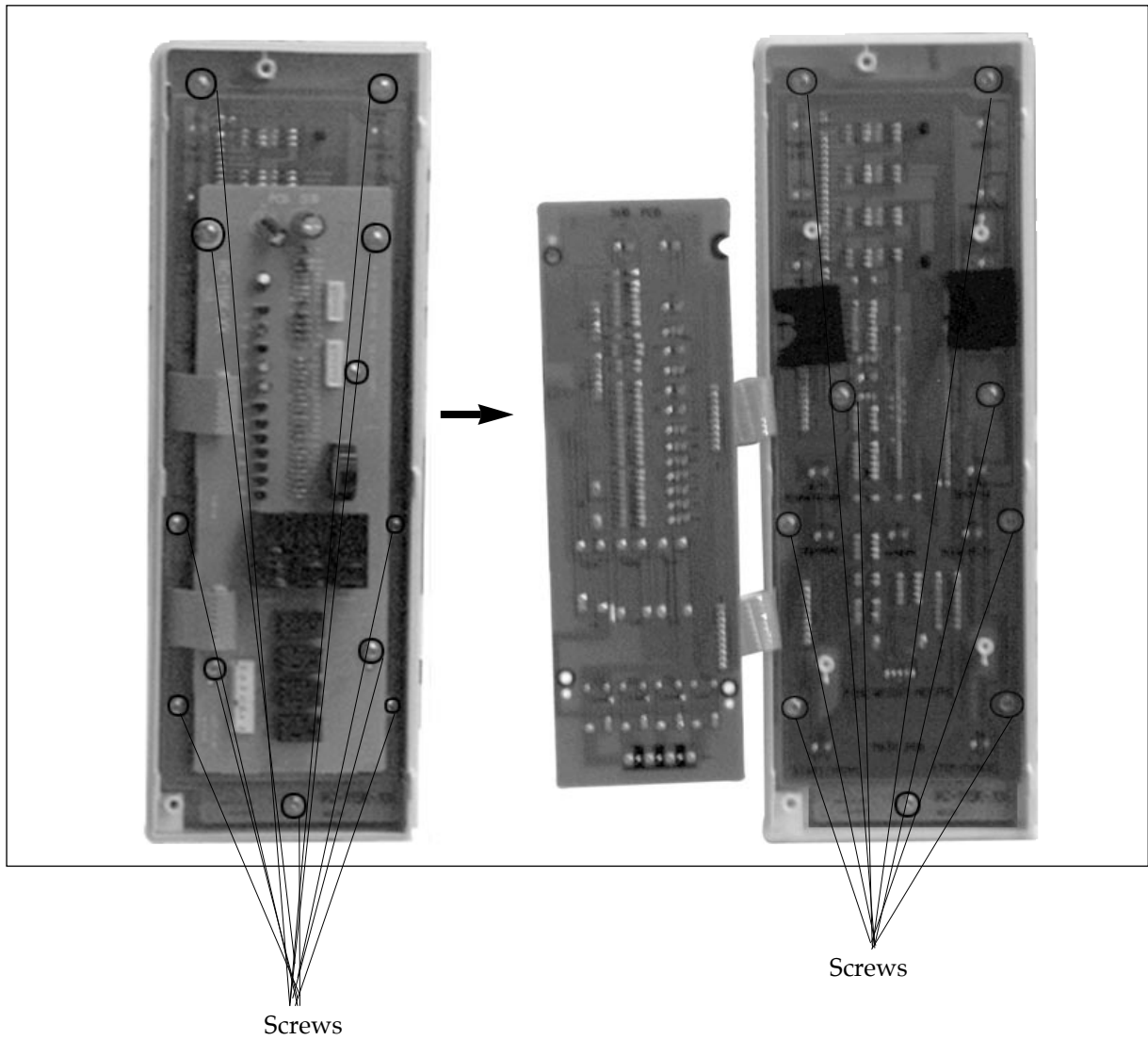

## 5. Alignment and Adjustments

### PRECAUTION

1. High voltage is present at the high voltage terminals during any cook cycle.
2. It is neither necessary nor advisable to attempt measurement of the high voltage.
3. Before touching any oven components or wiring, always unplug the oven from its power source and discharge the high voltage capacitor.

### 5-1 High Voltage Transformer

1. Remove connectors from the transformer terminals and check continuity.
2. Normal resistance readings are as follows:

H.V.T SPEC.	SHV-945EGI-AC-2
Secondary	86Ω ; 10%
Filament	Shows Continuity
Primary	1.5Ω ; 10%

(Room temperature = 20°C)

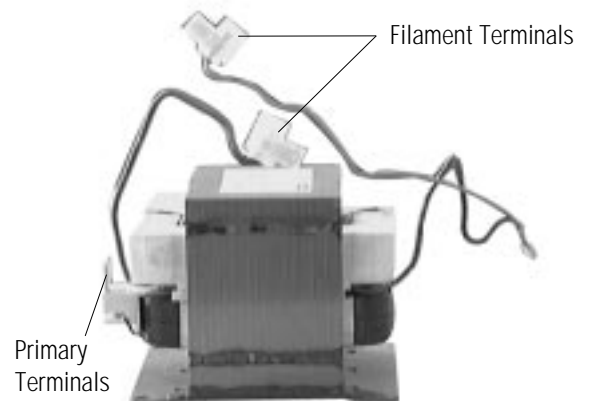

### 5-2 Low Voltage Transformer

1. The low voltage transformer is located on the control circuit board.
2. Remove the low voltage transformer from the PCB Ass'y and check continuity.
3. Normal resistor reading is shown in the table.

L.V.T SPEC. : SLV-105E	
Terminals	Resistance
1-2(Input)	290Ω
3-4(Output)	4.0Ω
5-6(Output)	1.0Ω

### 5-3 Magnetron

Continuity checks can indicate only an open filament or a shorted magnetron. To diagnose an open filament or shorted magnetron :

1. Isolate the magnetron from the circuit by disconnecting its leads.
2. A continuity check across the magnetron filament terminals should indicate one ohm or less.
3. A continuity check between each filament terminal and magnetron case should read open.

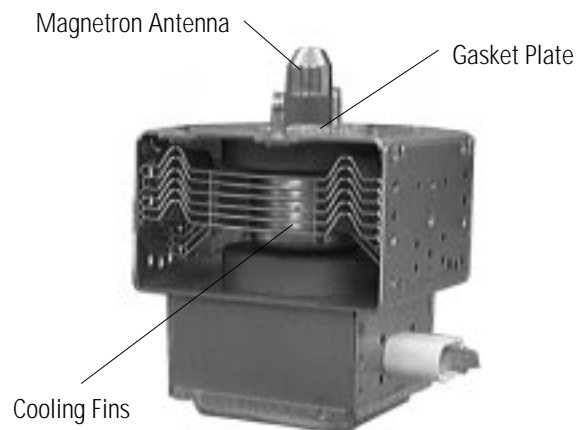

## 5-4 High Voltage Capacitor

1. Check continuity of the capacitor with the meter set at the highest resistance scale.
2. Once the capacitor is charged, a normal capacitor shows continuity for a short time, and then indicates  $9M\Omega$ .
3. A shorted capacitor will show continuous continuity.
4. An open capacitor will show constant  $9M\Omega$ .
5. Resistance between each terminal and chassis should read infinite.

## 5-5 High Voltage Diode

1. Isolate the diode from the circuit by disconnecting its leads.
2. With the ohm-meter set at the highest resistance scale, measure across the diode terminals. Reverse the meter leads and read the resistance. A meter with 6V, 9V or higher voltage batteries should be used to check the front-to back resistance of the diode (otherwise an infinite resistance may be read in both directions). The resistance of a normal diode will be infinite in one direction and several hundred  $K\Omega$  in the other direction.

## 5-6 Main Relay and Power Control Relay

1. The relays are located on the PCB Ass'y. Isolate them from the main circuit by disconnecting the leads.
2. Operate the microwave oven with a water load in the oven. Set the power level set to high.
3. Check continuity between terminals of the relays after the start pad is pressed.

## 5-7 Adjustment of Primary Switch, Door Sensing Switch and Monitor Switch

### Precaution

For continued protection against radiation hazard, replace parts in accordance with the wiring diagram and be sure to use the correct part number for the following switches: Primary and door sensing switches, and the interlock monitor switch (replace all together). Then follow the adjustment procedures below. After repair and adjustment, be sure to check the continuity of all interlock switches and the interlock monitor switch.

1. When mounting Primary switch and Interlock Monitor switch to Latch Body, consult the figure.  
NOTE: No specific adjustment during installation of Primary switch and Monitor switch to the latch body is necessary.
2. When mounting the Latch Body to the oven assembly, adjust the Latch Body by moving it so that the oven door will not have any play in it. Check for play in the door by pulling the door assembly. Make sure that the latch keys move smoothly after adjustment is completed. Completely tighten the screws holding the Latch Body to the oven assembly.
3. Reconnect to Monitor switch and check the continuity of the monitor circuit and all latch switches again by following the components test procedures.
4. Confirm that the gap between the switch housing and the switch actuator is no more than 0.5mm when door is closed.

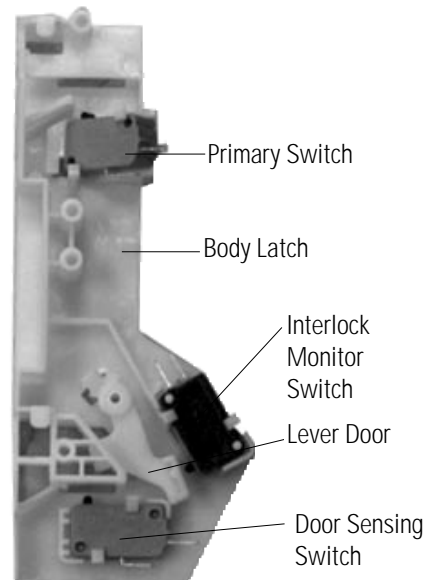

	Door Open	Door Closed
Primary switch	$\infty$	0
Monitor switch (COM-NC)	0	$\infty$
Monitor switch (COM-NO)	$\infty$	0
Door Sensing S/W	$\infty$	0

## 5-8 Output Power of Magnetron

### CAUTION MICROWAVE RADIATION

PERSONNEL SHOULD NOT ALLOW EXPOSURE TO MICROWAVE RADIATION FROM MICROWAVE GENERATOR OR OTHER PARTS CONDUCTING MICROWAVE ENERGY.

The output power of the magnetron can be measured by performing a water temperature rise test.

Equipment needed :

\* Two 1-liter cylindrical borosilicate glass vessel (Outside diameter 190 mm)

\* One glass thermometer with mercury column

NOTE: Check line voltage under load. Low voltage will lower the magnetron output. Make all temperature and time tests with accurate equipment.

1. Fill the one liter glass vessel with water.
2. Stir water in glass vessel with thermometer, and record glass vessel's temperature ("T1", 10±1°C).
3. After moving the water into another glass vessel, place it in the center of the cooking tray. Set the oven to high power and operate for 48seconds exactly. (1.5 seconds included as a holding time of magnetron oscillation:)
4. When heating is finished, stir the water again with the thermometer and measure the temperature ("T2").
5. Subtract T1 from T2. This will give you the water temperature rise. (ΔT)
6. The output power is obtained by the following formula;

$$\text{Output Power} = \frac{4.187 \times 1000 \times \Delta T + 0.88 \times Mc \times (T_2 - T_0)}{46.5}$$

46.5: Heating Time (sec)  
4.187 : Coefficient for Water  
1000 : Water (cc)  
ΔT : Temperature Rise (T2-T1)  
Mc : Cylindrical borosilicate glass weight  
T<sub>0</sub> : Room temperature.

7. Normal temperature rise for this model is 9°C to 11°C at 'HIGH'.

NOTE 1: Variations or errors in the test procedure will cause a variance in the temperature rise.

Additional power test should be made if temperature rise is marginal.

NOTE 2: Output power in watts is computed by multiplying the temperature rise (step 5) by a factor of 90 times the of centigrade temperature.

## 5-9 Microwave Heat Distribution - Heat Evenness

The microwave heat distribution can be checked indirectly by measuring the water temperature rise at certain positions in the oven:

1. Prepare five beakers made of 'Pyrex', having 100 milliliters capacity each.
2. Measure exactly 100milliliters off water load with a measuring cylinder, and pour into each beaker.
3. Measure the temperature of each water load. (Readings shall be taken to the first place of decimals.)
4. Put each beaker in place on the cooking tray as illustrated in figure below. Start heating.
5. After heating for 2 minutes, measure the water temperature in each beaker.
6. Microwave heat distribution rate can be calculated as follows:

$$\text{Heat Distribution} = \frac{\text{Minimum Temperature Rise}}{\text{Maximum Temperature Rise}} \times 100(\%)$$

The result should exceed 65%.

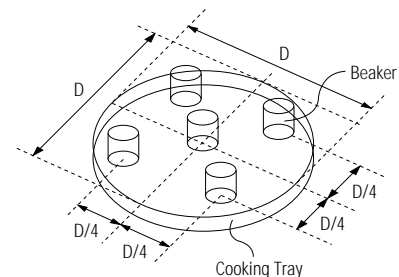

## 5-10 Procedure for Measurement of Microwave Energy Leakage

- 1) Pour 275 ± 15cc of 20 ± 5 °C (68 ± 9 °F) water in a beaker which is graduated to 600cc, and place the beaker in the center of the oven.
- 2) Start to operate the oven and measure the leakage by using a microwave energy survey meter.
- 3) Set survey meter with dual ranges to 2,450MHz.
- 4) When measuring the leakage, always use the 2 inch spacer cone with the probe. Hold the probe perpendicular to the cabinet door. Place the spacer cone of the probe on the door and/or cabinet door seam and move along the seam, the door viewing window and the exhaust openings moving the probe in a clockwise direction at a rate of 1 inch/sec. If the leakage testing of the cabinet door seam is taken near a corner of the door, keep the probe perpendicular to the areas making sure that the probe end at the base of the cone does not get closer than 2 inches to any metal. If it gets closer than 2 inches, erroneous readings may result.
- 5) Measured leakage must be less than 4mW/cm<sup>2</sup>, after repair or adjustment.

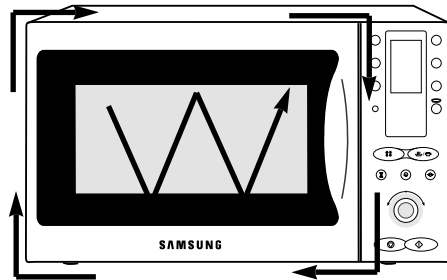

Maximum allowable leakage is 5mW/cm<sup>2</sup>.  
4mW/cm<sup>2</sup> is used to allow for measurement and meter accuracy

## 5-11 Check for Microwave Leakage

1. Remove the outer panel.
2. Pour 275±15cc of 20±5°C(68±9°F) water in a beaker which is graduated to 600cc, and place the beaker in the center of the oven.
3. Start the oven at the highest power level.
4. Set survey meter dual ranges to 2,450MHz.
5. Using the survey meter and spacer cone as described above, measure around the opening of magnetron, the surface of the air guide and the surface of the wave guide as shown in the following photo.( but avoid the high voltage components.) The reading should be less than 4mW/cm<sup>2</sup>.



**WARNING**  
AVOID THE HIGH VOLTAGE COMPONENTS.

## 5-12. Note on Measurement

- 1) Do not exceed the limited scale.
- 2) The test probe must be held on the grip of the handle, otherwise a false reading may result when the operator's hand is between the handle and the probe.
- 3) When high leakage is suspected, do not move the probe horizontally along the oven surface; this may cause damage to the probe.
- 4) Follow the recommendation of the manufacturer of the microwave energy survey meter.

## 5-13 Leakage Measuring Procedure

### 5-13-1 Record keeping and notification after measurement

- 1) After adjustment and repair of a radiation preventing device, make a repair record for the measured values, and keep the data.
- 2) If the radiation leakage is more than 4 mW/cm<sup>2</sup> after determining that all parts are in good condition, functioning properly and the identical parts are replaced as listed in this manual notify that fact to ;

**SAMSUNG ELECTRONICS COMERCIAL**  
**IBERICA, S. A**  
**VIA AUGUSTA, PARCELA 103**  
**08184 PALAU DE PLEGAMANS**  
**BARCELONA, ESPANA**

- 5-13-2 At least once a year have the microwave energy survey meter checked for accuracy by its manufacturer.

## 6. Troubleshooting

### PRECAUTION

1. CHECK GROUNDING BEFORE CHECKING FOR TROUBLE.
2. BE CAREFUL OF THE HIGH VOLTAGE CIRCUIT.
3. DISCHARGE THE HIGH VOLTAGE CAPACITOR.
4. WHEN CHECKING THE CONTINUITY OF THE SWITCHES OR TRANSFORMER, DISCONNECT ONE LEAD WIRE FROM THESE PARTS AND THEN CHECK CONTINUITY WITHOUT THE POWER SOURCE ON. TO DO OTHERWISE MAY RESULT IN A FALSE READING OR DAMAGE TO YOUR METER.
5. DO NOT TOUCH ANY PART OF THE CIRCUIT OR THE CONTROL CIRCUIT BOARD, SINCE STATIC DISCHARGE MAY DAMAGE IT. ALWAYS TOUCH GROUND WHILE WORKING ON IT TO DISCHARGE ANY STATIC CHARGE BUILT UP.

### 6-1 Electrical Malfunction

SYMPTOM	CAUSE	CORRECTIONS
Oven is dead. Fuse is OK. No display and no operation at all.	<ol style="list-style-type: none"> <li>1. Open or loose lead wire harness</li> <li>2. Open thermal cutout (Magnetron)</li> <li>3. Open low voltage transformer</li> <li>4. Defective Ass'y PCB</li> </ol>	<p>Check fan motor when thermal cutout is defective.</p> <p>Check Ass'y PCB when LVT is defective.</p>
No display and no operation at all. Fuse is blown.	<ol style="list-style-type: none"> <li>1. Shorted lead wire harness</li> <li>2. Defective primary latch switch (NOTE 1)</li> <li>3. Defective monitor switch (NOTE1)</li> <li>4. Shorted HVCapacitor</li> <li>5. Shorted HVTransformer (NOTE2)</li> </ol> <p>NOTE 1: All of these switches must be replaced at the same time. (refer to adjustment instructions) Check continuity of power relay contacts and if it has continuity, replace power relay also.</p> <p>NOTE 2: When HVTransformer is replaced, check diode and magnetron also.</p>	<p>Check adjustment of primary, interlock monitor, door sensing switch.</p>
Oven does not accept key input (Program)	<ol style="list-style-type: none"> <li>1. Key input is not in-Sequence</li> <li>2. Open or loose connection of membrane key pad to Ass'y PCB</li> <li>3. Shorted or open membrane panel</li> <li>4. Defective Ass'y PCB</li> </ol>	<p>Refer to operation procedure.</p> <p>Replace PCB main.</p>
Timer starts countdown but no microwave oscillation. (No heat while oven lamp and fan motor turn on.)	<ol style="list-style-type: none"> <li>1. Off-alignment of latch switches</li> <li>2. Open or loose connection of high voltage circuit especially magnetron filament circuit</li> </ol> <p>NOTE: Large contact resistance will bring lower magnetron filament voltage and cause magnetron to lower output and/or intermittent oscillation.</p> <ol style="list-style-type: none"> <li>3. Defective high voltage components H.V.Transformer H.V.Capacitor H.V.Diode,H.V.Fuse Magnetron</li> <li>4. Open or loose wiring of power relay</li> <li>5. Defective primary latch switch</li> <li>6. Defective power relay or Ass'y PCB</li> </ol>	<p>Adjust door and latch switches.</p> <p>Check high voltage component according to component test procedure and replace if it is defective.</p> <p>Replace PCB main.</p>

## 6-1 Electrical Malfunction(continued)

SYMPTOM	CAUSE	CORRECTIONS
Oven lamp and fan motor turn on	<ol style="list-style-type: none"> <li>1. Misadjustment or loose wiring of primary latch switch</li> <li>2. Defective primary latch switch</li> </ol>	Adjust door and latch switches.
Oven can program but timer does not start.	<ol style="list-style-type: none"> <li>1. Open or loose wiring of secondary interlock switch</li> <li>2. Off-alignment of primary interlock</li> <li>3. Defective secondary interlock S/W</li> </ol>	Adjust door and interlock switches.
Microwave output is low;. Oven takes longer time to cook food.	<ol style="list-style-type: none"> <li>1. Decrease in power source voltage.</li> <li>2. Open or loose wiring of magnetron filament circuit. (Intermittent oscillation))</li> <li>3. Aging of magnetron</li> </ol>	Consult electrician.
Fan motor turns on when plugged in	Loose wiring of door sensing switch	Check wire of door sensing switch.
Oven does not operate and return to the plugged in mode.	Defective Ass'y PCB	Replace PCB main.
Loud buzzing noise can be heard.	<ol style="list-style-type: none"> <li>1. Loose fan and fan motor</li> <li>2. Loose screws on H.V. Transformer</li> <li>3. Shorted H.V.Diode</li> </ol>	Tighten screws of fan motor. Tighten screws of H.V. Transformer. Replace H.V.Diode.
Turntable motor does not rotate.	<ol style="list-style-type: none"> <li>1. Open or loose wiring of turntable motor.</li> <li>2. Defective turntable motor.</li> </ol>	Check the wire of turntable motor Replace turntable motor.
Oven stops operation during cooking	<ol style="list-style-type: none"> <li>1. Open or loose wiring of primary interlock switch</li> <li>2. Operation of thermal cutout(Magnetron)</li> </ol>	Adjust door and latch switches.
Sparks	<ol style="list-style-type: none"> <li>1. Metallic ware or cooking dishes touching on the oven wall.</li> <li>2. Ceramic ware trimmed with gold or silver powder also causes sparks.</li> </ol>	Inform the customer.  Do not use any type of cookware with metallic trimming.
Uneven cooking	Uneven intensity of microwave due to its characteristics.	Wrap thinner parts of the food with aluminum foil. Use plastic wrap or cover with a lid. Stir once or twice while cooking foods such as soup, cocoa, or milk.
Noise from the turntable motor when it starts to operate.	Noise may result from the motor.	Replace turntable motor.

# 7. Exploded Views and Parts List

## 7-1 Exploded Views

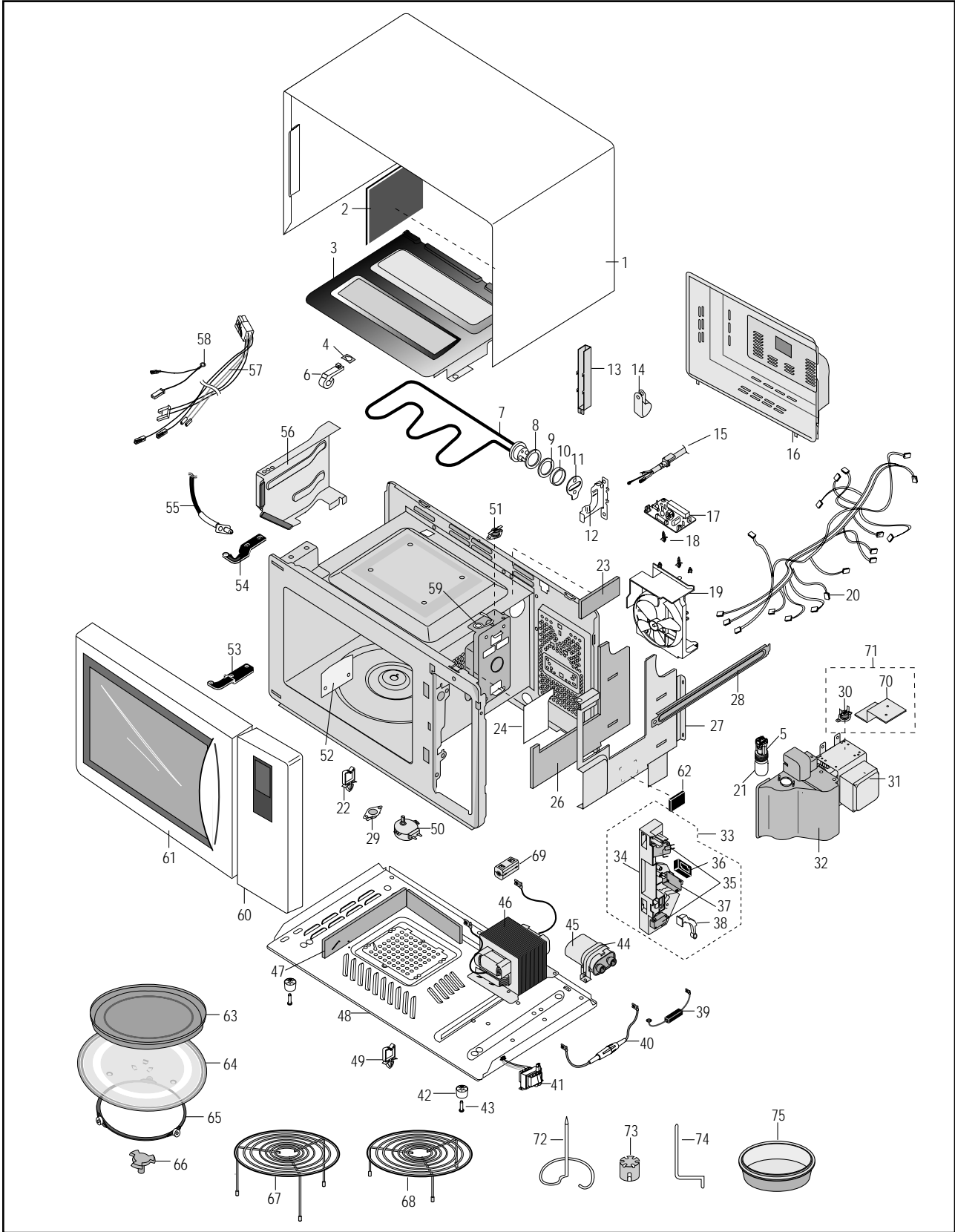

## 7-2 Main Parts List

Ref. No.	Parts No.	Description/Specification	Q'ty	Remarks
1	DE70-30029Z	PANEL-OUTER;SECC T0.6 W405.5 L1174.8 SC-WH	1	
2	DE63-90035G	CUSHION-RUBBER;DFA20 T2 W190 L100 BLK	1	
3	DE61-50073D	BRACKET-UPPER;ALSTAR T0.6 W273 L432 MB6544W	1	
4	DE61-70060A	SPRING-PLATE;SK-5 T0.5	1	
5	DE47-40029A	SOCKET-LAMP;250V2A 22.230 E14 BJB	1	
6	DE61-30185A	SUPPORTER-HEATER;ALUMINA T12 NTR	1	
7	DE47-70031B	HEATER-GRILL;D6.8 230V 1400W 37.00HM RE-130	1	
8	DE60-40009B	WASHER-TEFLON; SLOT ID22.2 OD28 T1.2 TEFLON	1	
9	DE63-20017A	GASKET-HEATER;BRASS T1.5 OD30.5 ID22.5	1	
10	DE60-90006A	FLANGE-RING;C3604BD ID22.1 OD26 L4.7 MBGF45	1	▲
11	DE61-50347A	BRACKET-EARTH;BSS2-A T1.0 W35 L43 MBGF45	1	
12	DE61-50027B	BRACKET-HEATER;SECC T1.0 W51 L55 CE945GF	1	
13	DE61-50076A	BRACKET-AIR GUIDE;ALCOAT T0.8 W61 L218.5	1	
14	DE65-20014A	CABLE-CLAMP;DA6-N NY 66	1	
15	DE39-20058B	ASSY POWER CORD;KKP-4819D/B232 1.5MM 250V16	1	
16	DE71-60386A	COVER-BACK;SCP3 T0.6 W275 L385.5 BLK-COATING	1	
17	DE91-40042A	ASSY NOISE FILTER;DNA-1019(C)250V 10A CMO-	1	
18	DE61-30129A	SUPPORT-P.C.B;DASS-T9N	2	
19	DE31-10080A	MOTOR-FAN;AMM92-002AUUEE 230V0.20A MIN2550RP	1	
20	DE39-40606A	ASSY WIRE HARNESS-A;230V50HZ CE105K/CE115K	1	
21	4713-000168	LAMP-INCANDESCENT;230V,-,25W,ORG,-,-,	1	● ▲ ● ▲
22	DE65-20025A	CABLE CLAMP;DAWS-2NB NYLON66 NTR WIRE SADDL	1	
23	DE63-90065E	CUSHION-LAMP;PUT-FOAM T40 W10 L90 M6245	1	
24	DE01-00051A	FILM-LAMP;T0.25 W105 L85 CLEAR RE-1300	1	▲
26	DE62-90046A	ADIABATIC-RIGHT;T3 W219.3 L214.8 RE-1300	1	
27	DE71-60294A	COVER-ADIABATIC;SECC T0.6 W249.7 L353.5 RE-1300	1	
28	DE61-30132A	SUPPORTER-MGT;SECC T0.6 W38 L342.5 MW6630T	1	
29	DE47-20005A	THERMOSTAT;PW-2N(130/60) 187Y30 250V7.5A 130	1	
30	DE47-20007A	THERMOSTAT;PW-2N(160/60) 187Z 250V 7.5A 160	1	
31	DE03-30035A	MAGNETRON;OM75PH(31)ESS	1	
32	DE92-90213A	ASSY COVER-AIR; RE-1300	1	
33	DE93-20020A	ASSY BODY LATCH;RE-43B/90B	1	
34	DE66-40021A	LATCH-BODY;POM (F20-02) 50G RE-330	1	
35	3405-000178	SW-MICRO;VP-533A-OF-PS(T85) 250V,15A,20	2	
36	DE72-60106A	GUIDE-S/W;ABS BLK	1	
37	3405-000175	SW-MICRO;VP-531-OF (T85) 250V,15A,200GF	1	
38	DE66-90054A	LEVER-SWITCH;POM(F20-02) 15G NTR RE-330	1	
39	DE59-40001A	DIODE-H.V;HVR-1X-32B-12	1	
40	DE91-70061A	ASSY-H.V.FUSE;THV060T-0800-H 5KV/0.8A RED	1	

● : Option Parts

▲ : Warning

▲ :Electrostatically Sensitive Devices

## 7-2 Main Parts List

Ref. No.	Parts No.	Description/Specification	Q'ty	Remarks
41	DE26-20152A	TRANS-L.V;SLV-105E 230V 50HZ AC17V/3V	1	
42	DE61-40026A	FOOT;P.P JI350 BLK	4	
43	DE60-60025A	PIN-FOOT;P.P-JI350BLK	4	
44	DE61-50106A	BRACKET-H.V.C;SECC T0.8 W31 L125.8	1	
45	2501-001030	C-OIL;1.1uF,2100V,BK,35x54x95,20mm	1	
46	DE26-10100D	TRANS-H.V;SHV-945EG1-2 230V50HZ 2300V/DPC	1	
47	DE63-90065J	CUSHION-GUIDE;PUT FOAM T40 W10 L460 MX246	1	
48	DE80-10031B	BASE-PLATE;SGCC1-Z T0.8 W375 L588 RE-1300	1	
49	DE65-20025A	CABLE-CLAMP;DAWS-2NB NYLON66 NTR WIRE SADDL	1	
50	DE31-10170A	MOTOR-DRIVE;M2LJ24Z702 ST-16F 220/240V 2.5/	1	
51	DE47-20050A	THERMOSTAT;PW-2N 130/60	2	
52	DE71-60313A	COVER-CEILING;MICA SHEET T0.5 W48.5 L117 RE-1300	1	
53	DE61-80006B	HINGE-LOWER;ZP2W T3.0 ZN(PLATING) RE-552	1	
54	DE61-80037C	HINGE-UPPER;SCP1 T3.0 W26 L76 ZP2C-W MB245	1	
55	DE32-10013A	SENSOR-THERMISTOR;PT-312-K2	1	
56	DE72-60035Q	GUIDE-AIR;SECC (T)0.6 (W)240 (L)242 5 RE-13	1	
57	DE39-40637A	WIRE HARNESS-B;230V50HZ CE115K	1	
58	DE39-40409A	WIRE HARNESS-E;230V50HZ M9G45 CTW	1	
59	DE65-20012A	CORD-CLAMP;DALC-2-1 SILICON	1	
60		ASSY CONTROL-BOX	1	
61		ASSY DOOR	1	
62	DE63-90062A	CUSHON-RUBBER DOOR;RUBBER(CR) T9 W30 L50	1	
63	DE74-20025C	TRAY-CONVECTION;SPP T0.8 W12 L325.9 CE104CF	1	
64	DE74-20016A	TRAY-COOKING;GLASS T5.0 PI345 1250G M551T	1	
65	DE92-90189C	ASSY-GUIDE ROLLER;D22.5 RE-1300	1	
66	DE67-60028A	COUPLER;PTFE 20G WHT RE-1300	1	
67	DE92-90019P	ASSY-WIRE RACK;CE1279KSE HIGH	1	
68	DE92-90019R	ASSY-WIRE RACK;CE1279KSE LOW	1	
69	DE73-90027A	FERRITE-CORE;NI-ZN T13.8 W21.0 L28.0 BNF-14	1	
70	DE61-50490A	BRACKET-TCO;SECC1 T0.6 34 58	1	
71	DE91-70101B	ASSY THERMOSTAT;RE-542 160/60 187 TYPE	1	
72	DE74-40001A	SPIT-BARBECUE;MSWR CE945G SNC2	1	
73	DE67-60074A	COUPLER-BARBECUE;PTFE 29G WHT CE104CF	1	
74	DE72-80062A	SHAFT-BARBECUE;STS304 D3 L149 W60.25 CE97	1	
75	DE74-20022A	TRAY-OIL;GLASS(NEOREX) T5 PI210 600G	1	

### 7-3 Exploded View & Parts List - Door Parts

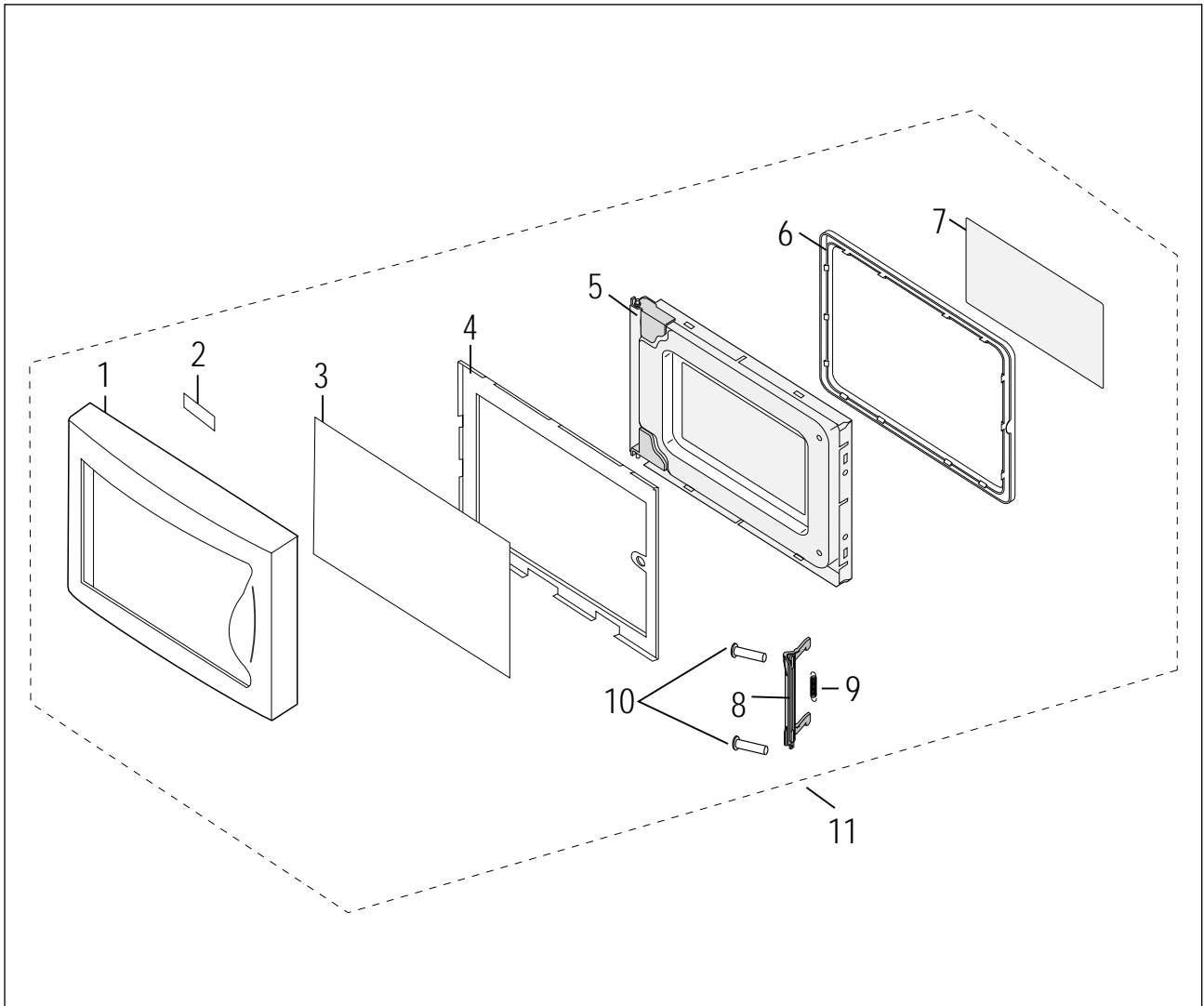

Ref. No.	Parts No.	Description/Specification	Q'ty	Remarks
1	DE64-20117A	HANDLE-DOOR;PC WHT 30G CE115K	1	
2	DE02-00082A	TAPE-DOUBLE FACE;PET T0.4 W9 WHT SEIL SI-500HI	1	
3	DE64-40279A	DOOR-A;PC WHT 300G CE115K	1	
4	D64-40286A	DOOR-SUB;PC T2.0 W267.6 L402.6 100G BLK CE1	1	
5	DE92-50080E	ASSY DOOR-E;MBG45 COATING SIL/SELANT	1	
6	DE64-40173A	DOOR-C;PBT BLK 24G RE-1300	1	
7	DE67-20163A	SCREEN-DOOR(B);TEMP GLASS T3.2 W261.6 L397	1	
8	DE64-40175A	DOOR-KEY;POM(TC3005) BLK 13G RE-	1	
9	DE61-70041B	SPRING-KEY;ES HSW3 P10.7 D4.9 BLUING RE-751	1	
10	DE60-60008F	PIN-HINGE;PI4 L15 NYLON#66 CE115K BLK	2	
11	DE92-40185A	ASSY DOOR;CE115K(SAW) WHT VITALITY	1	

## 7-4 Exploded View & Parts List - Control Parts

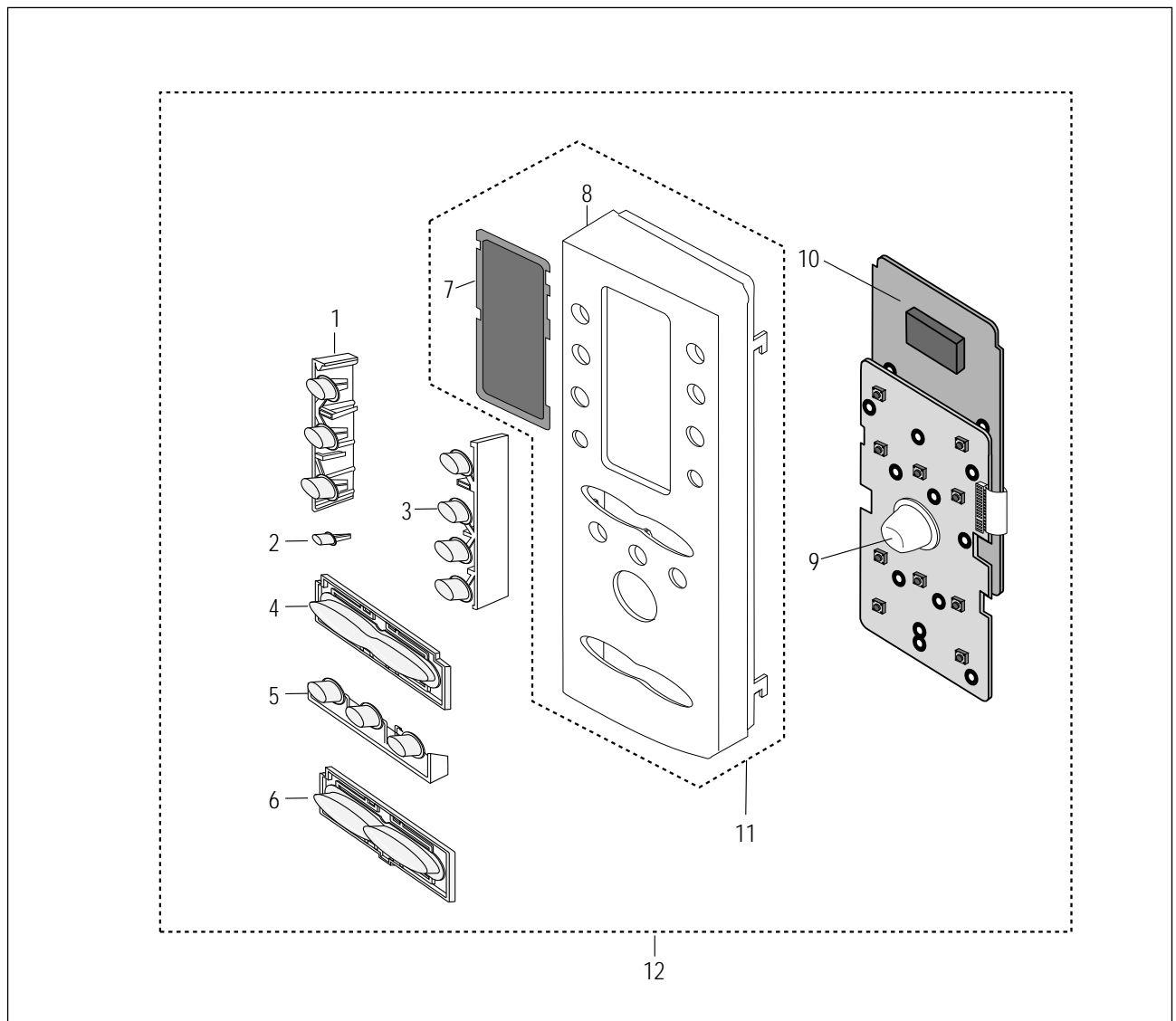

Ref. No.	Parts No.	Description/Specification	Q'ty	Remarks
1	DE66-20192A	BUTTON-SELECT-A;PC WHT 20G CE115K	1	
2	DE66-20195A	BUTTON-CLOCK;PC WHT 5G CE115K	1	
3	DE66-20196A	BUTTON-SELECT-B;PC WHT 15G CE115K	1	
4	DE66-20194A	BUTTON-DEFROST;PC WHT 20G CE115K	1	
5	DE66-20191A	BUTTON-MORE;PC WHT 13G CE115K	1	
6	DE66-20193A	BUTTON-CANEL;PC WHT 20G CE115K	1	
7	DE67-40150K	WINDOW-DISPLAY;ACRYL WHT 30G CE117KB/XEC	1	
8	DE72-70185T	CONTROL-PANEL;PC WHT 230G CE117KB/XEC	1	
9	DE64-10132A	KNOB;PC WHT 10G CE115K	1	
10	DE91-10462A	ASSY P.C.B-MAIN;230V50HZ S VFD CE115K/117K	1	
11	DE93-30457B	ASSY CONTROL-PANEL;CE117KB/XEC WHT	1	
12	DE93-30419P	ASSY CONTROL-BOX;230V50HZ CE117KB/XEC WHT SECOSA	1	

### 7-5 Exploded View & Parts List - Casing Parts

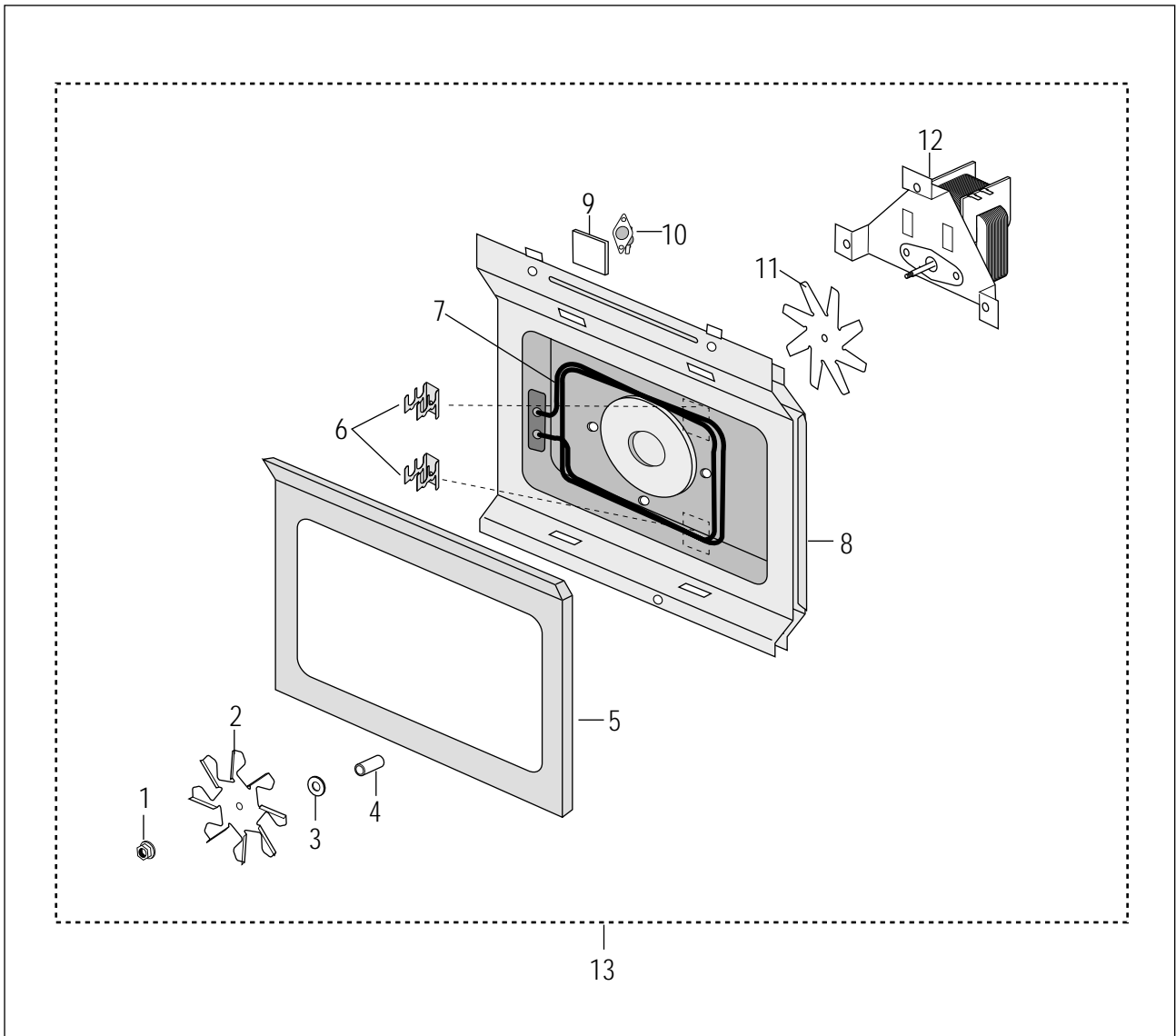

Ref. No.	Parts No.	Description/Specification	Q'ty	Remarks
1	DE60-30016B	NUT-FLANGE;M4 MSWR10 FEFN	1	i
2	DE31-90020A	BLADE-FAN;ALSTAR T0.6 W250 L250	1	i
3	DE60-40026B	WASHER-PLAIN;ID5.5 OD12 T1.0 SBC1ZNC3	1	i
4	DE72-30016B	BUSH-MOTOR;MSWR3 D5.6 L15.7 CE115K	1	i
5	DE62-90098A	ADIABATIC-CASING;T5 W245 L336.8 CE115K	1	i
6	DE61-50484A	BRACKET-HEATER;STS430 T0.8 W27.2 L26 CE115K	1	i
7	DE47-70077A	HEATER-CONVECTION;230V 1680W 30.7 7.0	1	
8	DE92-90487A	ASSY-COVER CASING;CE115K 230V50HZ	1	
9	DE62-10014A	INSULATION-TCO;T2.0 W34 L26 YEL	1	
10	DE47-20029A	THERMOSTAT;PW-2N(160/60,Y,23.8) 250V/7.5A	1	
11	DE31-90019A	BLADE-FAN;SECC T0.6	1	
12	DE31-10171A	MOTOR-CONVECTION;SMC-105EA 230V/50HZ 2800RP	1	
13	DE92-90478A	ASSY-CASING;CE115K/CE105K 230V50HZ	1	

## 7-6 Parts List - Standard Parts

Parts No.	Description/Specification	Q'ty	Remarks
DE60-10098A	SCREW-ASSY TAPTITE;PH TC M4X8 SWRCH18A Z	2	CV-TCO
DE60-10098A	SCREW-ASSY TAPTITE;PH TC M4X8 SWRCH18A Z	2	M/DRIV
DE60-10082H	SCREW-A;2S-4X12(TOOTHED)	1	CV/AIR
DE60-10082H	SCREW-A;2S-4X12(TOOTHED)	2	SW-THE
DE60-20014A	BOLT-FLANGE;M5 L10 MSWR3 FEFZY	4	HINGE
DE60-10046A	SCREW-TAP PH;PH M3 L8 FEFZY	2	MGTCO
DE60-10052A	SCREW-TAP PH;PH M4 L8 FEFZY	1	B/HING
DE60-10080A	SCREW-WASHER;M5 L12 2S	4	HVT
DE60-10082H	SCREW-A;2S-4X12(TOOTHED)	9	BASE-
DE60-10012A	SCREW-TAP TITE;TH + 3 M4 L10 SWR10 ZPC2	3	GROUP
DE60-10013A	SCREW-ASSY TAP;TH 2S 4 L12 MSWR3 ZPC3 FI	4	CV-MOT
DE60-10018A	SCREW-ASSY MACHINE;PH M4X0.7P 8 MSWR10 S	2	B/EART
DE60-10012A	SCREW-TAP TITE;TH + 3 M4 L10 SWR10 ZPC2	1	HVD
DE60-10082H	SCREW-A;2S-4X12(TOOTHED)	1	B/C-MO
DE60-10082H	SCREW-A;2S-4X12(TOOTHED)	2	LVT
DE60-10088A	SCREW-TAP PH;PH M3 L8 FEFZY PLAIN	5	PCB
DE60-10034A	SCREW-TH;TH + M4 L10 STS304	1	SENSOR
DE60-10082H	SCREW-A;2S-4X12(TOOTHED)	2	CV-BAK
DE60-10082H	SCREW-A;2S-4X12(TOOTHED)	1	BKT/U
DE60-10122A	SCREW-TAP TH;TAP TH 2-4X8 FE FN	2	B/HEAT
DE60-10122A	SCREW-TAP TH;TAP TH 2-4X8 FE FN	2	C-CEIL
DE60-10080A	SCREW-WASHER;M5 L12 2S	4	MGT
DE60-10082H	SCREW-A;2S-4X12(TOOTHED)	2	CN-BOX
DE60-10082H	SCREW-A;2S-4X12(TOOTHED)	1	CV/AIR
DE60-10082H	SCREW-A;2S-4X12(TOOTHED)	1	SU/MGT
DE60-10082H	SCREW-A;2S-4X12(TOOTHED)	2	SW-THE
DE60-10082H	SCREW-A;2S-4X12(TOOTHED)	5	PN-OUT
DE60-10082H	SCREW-A;2S-4X12(TOOTHED)	4	A/CSIG
DE60-10082H	SCREW-A;2S-4X12(TOOTHED)	2	B/LATH
DE60-10082H	SCREW-A;2S-4X12(TOOTHED)	1	B/WAVE
DE60-10098A	SCREW-ASSY TAPTITE;PH TC M4X8 SWRCH18A Z	4	AS-CSI
DE60-10082H	SCREW-A;2S-4X12(TOOTHED)	1	B/AI-G
DE60-30016B	NUT-FLANGE;M4 MSWR10 FEFN	1	SENSOR
DE60-10013A	SCREW-ASSY TAP;TH 2S 4 L12 MSWR3 ZPC3 FI	1	CB-CMP
DE60-10082H	SCREW-A;2S-4X12(TOOTHED)	2	GU-AIR

# 8. P.C.B Diagrams

## 8-1 P.C.B Diagrams

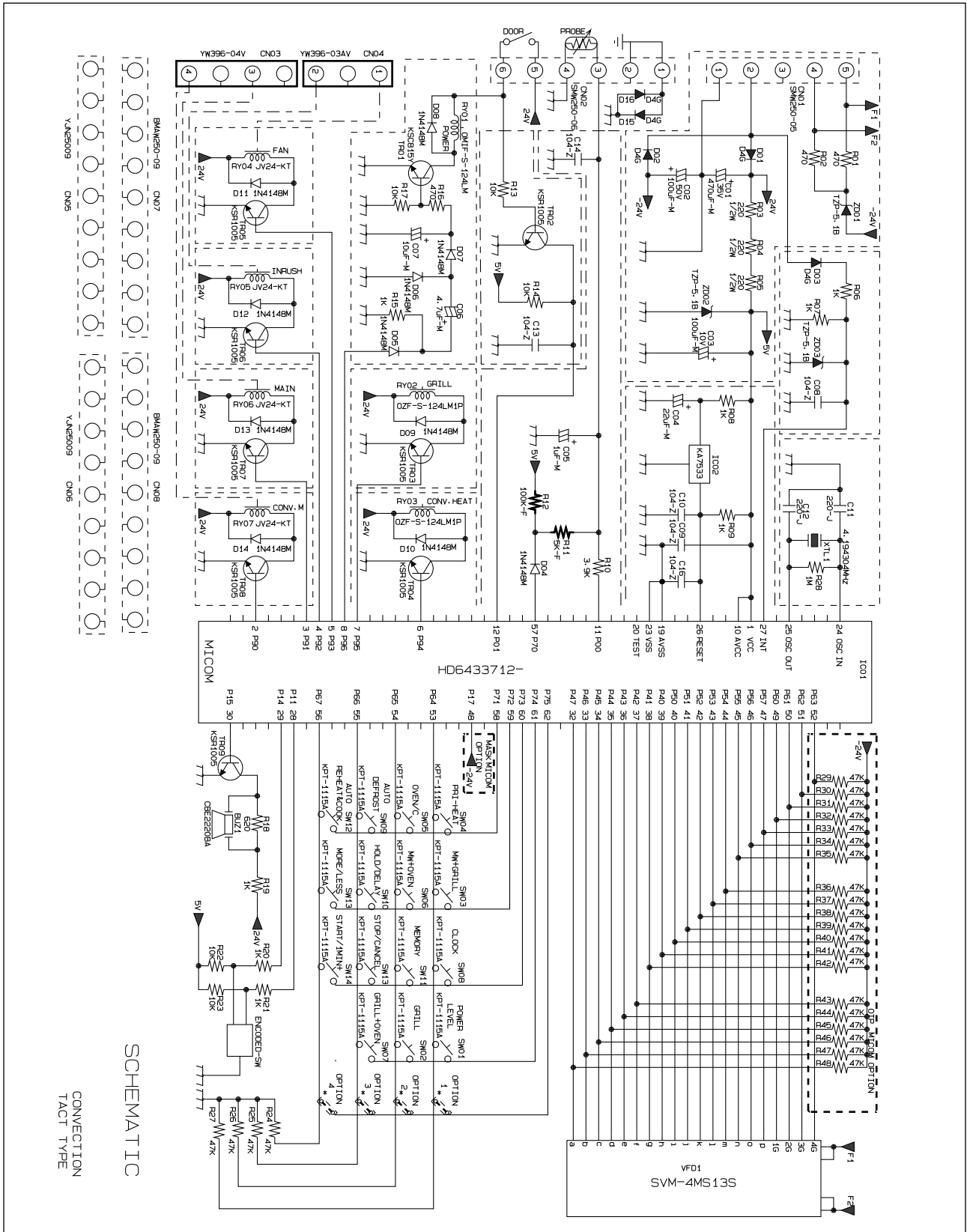

## 8-2 P.C.B Parts List

Parts No.	Description / Specification	Q'ty	Remarks
3406-000175	SWITCH-ROTARY;28V,10mA,DP36T,18.8mm	1	ECD1
3501-001014	RELAY-POWER;24V,21.8mA,17A,1FormA,20mS,8mS	1	RY01
3501-001015	RELAY-POWER;24V,21.8mA,16A,1FormA,20mS,10m	2	RY02,RY03
3501-001016	RELAY-MINIATURE;24V,12.5mA,5A,1FormA,8mS,4mS	4	RY04-RY07
3710-000246	CONNECTOR-SOCKET;9P,1R,2.5mm,STRAIGHT,SN	2	CN07,CN08
DE07-10052A	V.F.DISPLAY;SVM-4MS13S,MWO,RE-1280	1	VFD1
DE09-30614A	IC-MCU;HD6433712C85Q,16K,DIP	1	IC01
DE30-20016A	BUZZER;CBE2220BA,STICK	1	BUZ1
DE37-90019A	CONNECTOR ASSY;YJN25009,PLATE,73MM,WHT	2	CN05,CN06
DE61-90034D	HOLDER-DIGITRON;PP(JI350),BLK	1	
DE91-20503A	ASSY PCB AUTO-MAIN;230V50HZ,CE115K	1	
0401-001002	DIODE-SWITCHING;1N4148M,100V,200mA,500mW,3nS,D	10	D04-D13
0402-001103	DIODE-RECTIFIER;1T4,400V,1A,TS-1,TP	6	D01-D03,D15-D16
0403-000525	DIODE-ZENER;1N4733A,5.1V,5%,1W,DO-41,TP	3	ZD01-ZD03
0501-000388	TR-SMALL SIGNAL;KSC815,NPN,400mW,TO-92,BK,120	1	TR01
0504-001014	TR-DIGITAL;KSR1005,NPN,300mW,4.7K-10K,TO	8	TR02-TR09
2001-000290	R-CARBON;10Kohm,5%,1/8W,AA,TP,1.8x3.2mm	5	R13,R14,R17,R22,R23
2001-000429	R-CARBON;1Kohm,5%,1/8W,AA,TP,1.8x3.2mm	8	R06-R09,R15,R19-R21
2001-000435	R-CARBON;1Mohm,5%,1/8W,AA,TP,1.8x3.2mm	1	R28
2001-000613	R-CARBON;3.9Kohm,5%,1/8W,AA,TP,1.8x3.2m	1	R10
2001-000780	R-CARBON;470ohm,5%,1/8W,AA,TP,1.8x3.2mm	3	R01,R02,R16
2001-000786	R-CARBON;47Kohm,5%,1/8W,AA,TP,1.8x3.2mm	4	R24-R27
2001-000904	R-CARBON;620ohm,5%,1/8W,AA,TP,1.8x3.2mm	1	R18
2001-001107	R-CARBON(S);220ohm,5%,1/2W,AA,TP,2.4x6.4mm	3	R03-R05
2004-000195	R-METAL;100Kohm,1%,1/8W,AA,TP,1.8x3.2m	1	R12
2004-001118	R-METAL;5Kohm,1%,1/4W,AA,TP,2.4x6.4mm	1	R11
2202-000205	C-CERAMIC,MLC-AXIAL;22pF,5%,50V,SL,TP,1.9x3.5	2	C11,C12
2202-000780	C-CERAMIC,MLC-AXIAL;100nF,+80-20%,50V,Y5V,TP,3.5x1	5	C08-C10,C13,C14
2401-000247	C-AL;100uF,20%,10V,GP,-,6.3x11mm,5m	2	C03,C15
2401-000353	C-AL;100uF,20%,50V,GP,-,10x16x5mm	1	C02
2401-000446	C-AL;10uF,20%,25V,GP,-,5x11x5.0mm	1	C07
2401-000598	C-AL;1uF,20%,50V,GP,TP,4x7,5	1	C05
2401-000914	C-AL;22uF,20%,16V,-,TP,5x11,5mm	1	C04
2401-001268	C-AL;4.7uF,20%,50V,GP,-,5x11mm,5mm	1	C06
2401-001424	C-AL;470uF,20%,35V,WT,-,13x21x7.5mm	1	C01
2801-000271	CRYSTAL-UNIT;4.194304MHz,50ppm,28-AAM,12pF,	1	XTL1
3404-001022	SWITCH-TACT;15V,20mA,130°±40gf,6x6x5mm,SPS	15	SW01-SW15
3711-000203	CONNECTOR-HEADER;1WALL,3P,1R,3.96mm,ANGLE,SN	1	CN04
3711-000240	CONNECTOR-HEADER;1WALL,4P,1R,3.96mm,STRAIGHT,SN	1	CN03
3711-000999	CONNECTOR-HEADERBOX,5P,1R,2.50mm,STRAIGHT,SN	1	CN01
3711-001038	CONNECTOR-HEADERBOX,6P,1R,2.5mm,STRAIGHT,SN	1	CN02
DE13-20009A	ICKA7533,DIP	1	IC02 ▲
DE39-60001A	WIRE-SO COPPER;PI0.6,SN,T,52MM,TAPING_WIRE	20	J01-J19,J27

# 9. Schematic Diagrams

## 9-1 Schematic Diagrams

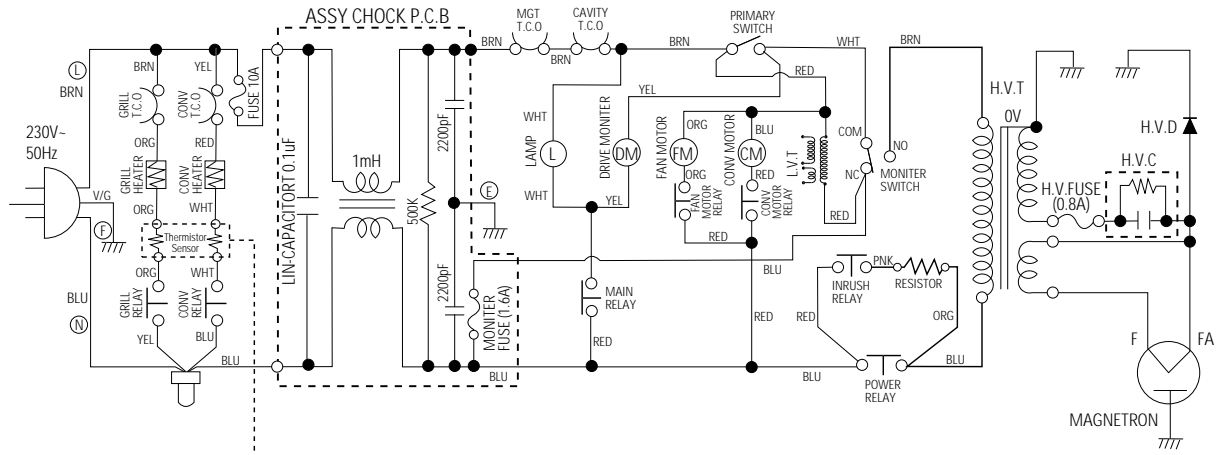

**CONDITION OF OVEN**

DOOR IS OPENED  
COOK OFF

**WIRING COLOR**

BRN : BROWN  
WHT : WHITE  
RED : RED  
Y/G : YELLOW/GREEN  
BLU : BLUE  
ORG : ORANGE  
YEL : YELLOW  
PNK : PINK

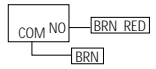
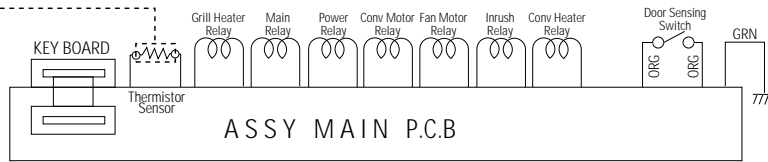

PRIMARY LATCH SWITCH

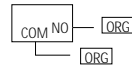

DOOR SENSING SWITCH

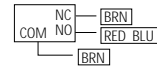

MONITOR SWITCH

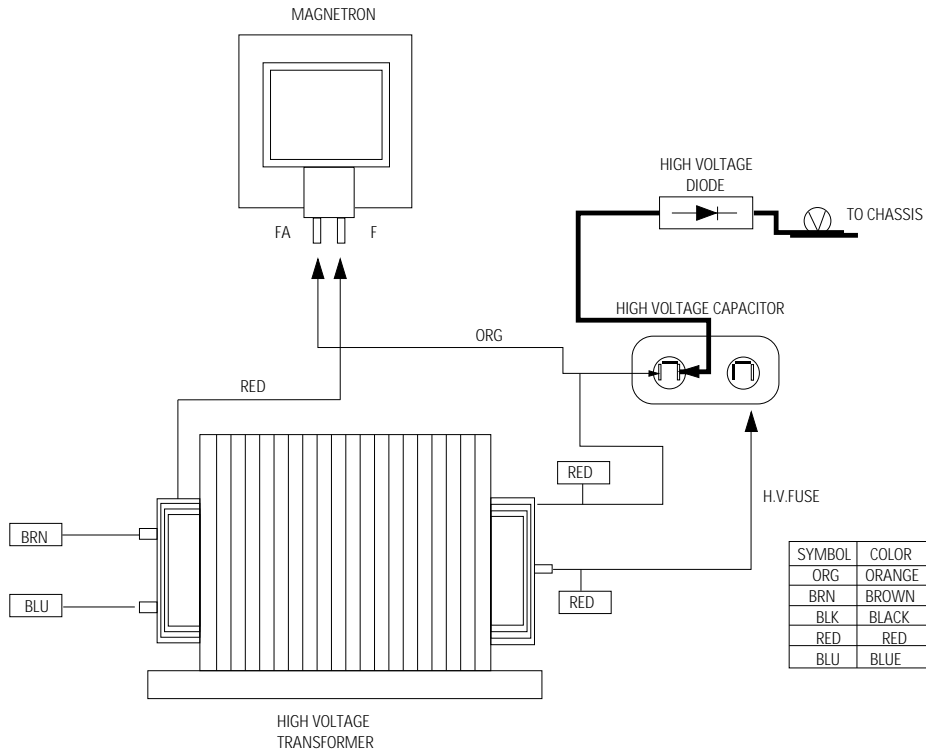

SYMBOL	COLOR
ORG	ORANGE
BRN	BROWN
BLK	BLACK
RED	RED
BLU	BLUE